

RoHS2.0  
Compliant

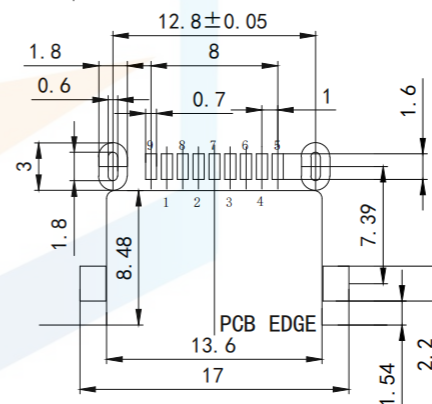
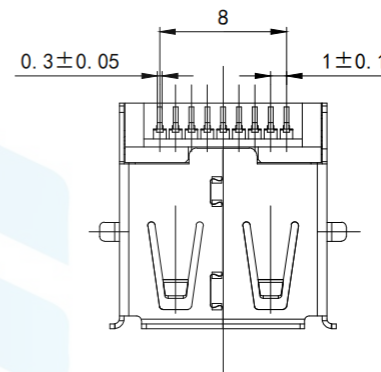
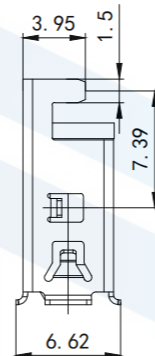
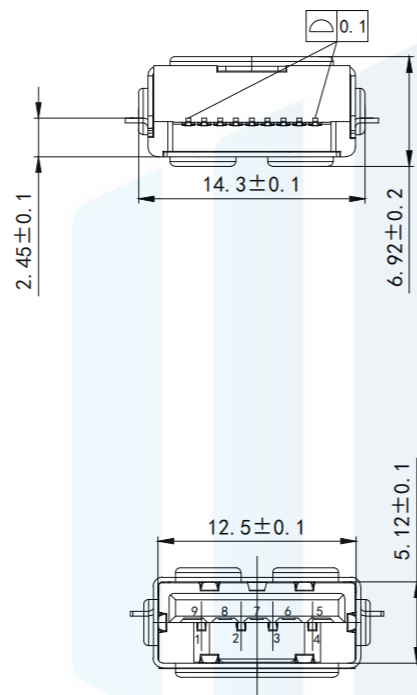
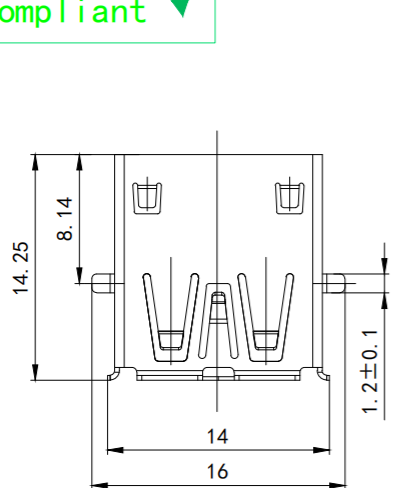

RECOMMENDED PCBA LAYOUT  
(TOLERANCE+±0.05)

NOTE:

1. MATERIAL:

- 1.1 INSULATOR: LCP UL 94V-0
- 1.2 CONTACT: BRONZE (T=0.20mm)
- 1.3 SHELL: SUS201 (T=0.30mm)

2. ELECTRICAL CHARACTERISTICS;

- 2.1 CONTACT RESISTANCE: 30mΩ MAXIMUM
- 2.2 CONTACT CURRENT RATING: 1.5A
- 2.3 DIELECTRIC WITHSTANDING VOLTAGE: 500 V

R. M. S.

- 2.4 INSULATION RESISTANCE 1000 MEGOHMS MIN
- 2.5 OPERATING TEMPERATURE: -40° C ~ 85° C

3 MECHANICAL CHARACTERISTICS:

- 3.1 MATING FORCE: 3.57kg MAX
- 3.2 UNMATED FORCE: 1.02kg MIN
- 3.3 DURABILITY: MANDATORY: 5,000 CYCLES

4. PLATING

- 4.1 TERMINAL:
  - 50u" MIN NICKEL ALL OVER
  - 100u" MIN Tin ON SOLDER AREA
  - (1~30)u" Au ON CONTACT AREA
- 4.2 SHELL: 100u" MIN. NICKEL ALL OVER

|                  |       |   |  |                                  |                       |
|------------------|-------|---|--|----------------------------------|-----------------------|
| <b>TOLERANCE</b> |       |   | <b>东莞市恒祺电子科技有限公司</b>                           |                                  |                       |
| X. XXX           | ±0.05 |   | Dongguan Hengqi Electronic Technology Co., Ltd |                                  |                       |
| X. XX            | ±0.15 | <a href="https://www.hq-dz.com">https://www.hq-dz.com</a> |  | phone: 15812872448               |                       |
| X. X             | ±0.20 | <b>TITLE:</b>   |  | <b>PART NO:</b> USB3.0-X133      |                       |
| X.               | ±0.30 | USB3.0 A/F 沉板2.45贴片卷边                                     |  | <b>DRAWING NO:</b> 14.25*16*6.92 |                       |
| ANGLE            | ±5.0° | 定位脚前贴后插L=14.25  |  |                                  |                       |
| <b>PROTECTON</b> |       | <b>DRAWN:</b>   | <b>DATE:</b>                                   | 18-10-08                         | <b>UNIT:</b><br>mm    |
|                  |       | <b>CHECKED:</b>   | <b>DATE:</b>                                   | 18-10-08                         | <b>SCALE:</b><br>FULL |
|                  |       | <b>APPROVED:</b>  | <b>DATE:</b>                                   | 18-10-08                         | <b>SIZE:</b><br>A4    |