

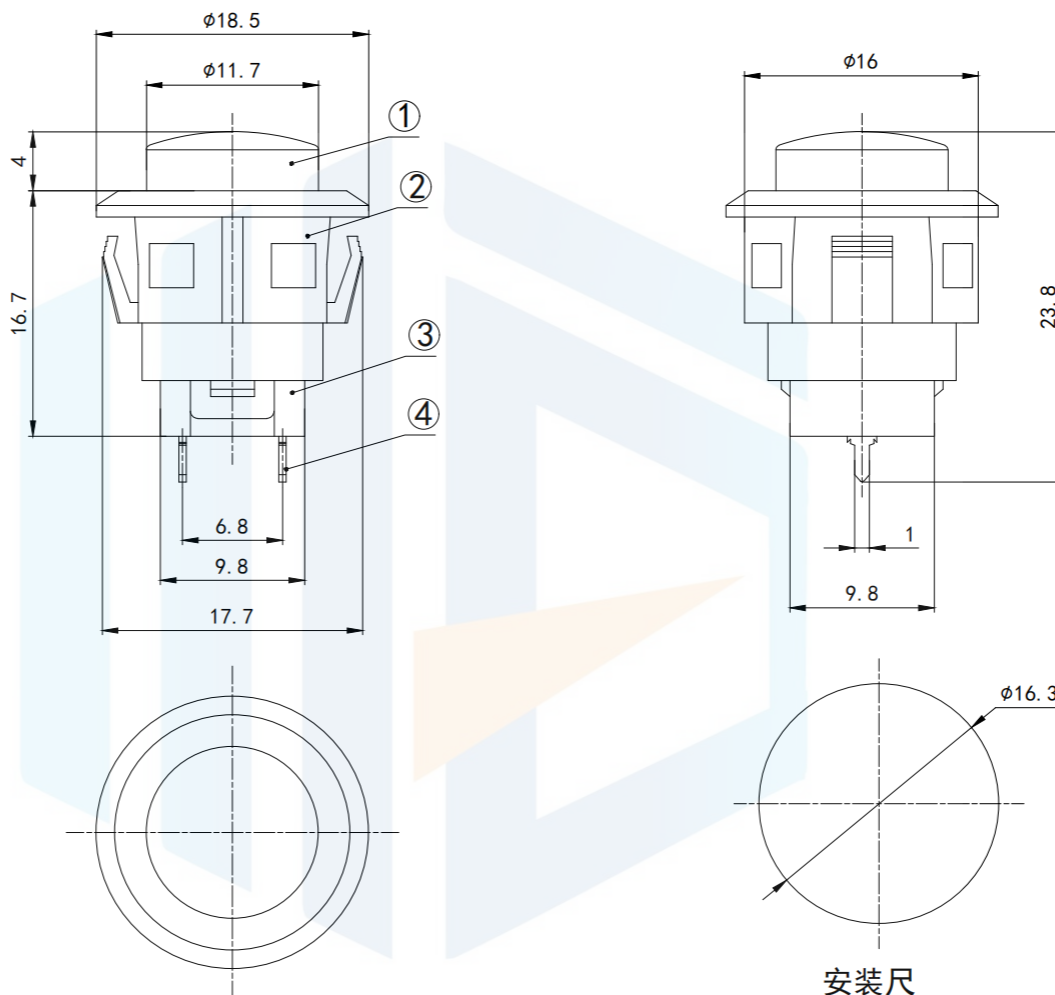

RoHS2.0  
Compliant

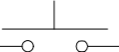

安装尺

### The Main hchnology

1. Circuit: 
2. Rated voltage: 1.5A 250V<sup>~</sup>  
Rated current: 3A 125V<sup>~</sup>
3. Insulated resistance:  $\geq 100M\Omega$
4. Contact resistance:  $\leq 100M\Omega$
5. Dielectric strength:  $\geq 500V/5S$
6. Endurance:  $\geq 10000$ 次
7. Ambient temperature: T85

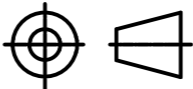
TOLERANCE	X. XXX	±0.05	 东莞市恒祺电子科技有限公司 Dongguan Hengqi Electronic Technology Co., Ltd				
	X. XX	±0.15				<a href="https://www.hq-dz.com">https://www.hq-dz.com</a>	
X. X	±0.20	TITLE: 按钮开关			PART NO: PBS-510		
X.	±0.30	DRAWN: CHECKED: APPROVED:			DRAWING NO: 18.5*23.8		
ANGLE	±5.0°				DATE:	18-10-08	UNIT: mm
					DATE:	18-10-08	SCALE: FULL
		DATE:	18-10-08	SIZE: A4			