

RoHS2.0
Compliant

NOTE:

MATERIAL SPECIFICATION:

1. HOUSING: LCP UL94 V-0.

COLOR BLACK

2. CONTACTS: COPPER

ALLOY (BRASS)

3. SHELL: SPCC

SPECIFICATIONS:

Contact current Rating: 1A
mperes

Dielectric Withstanding
Voltage: AC 100V (RMS)

Insulation

resistance: 100Megohms

Minimum. Contact

Resistance:

30m ohm Max for pin1~pin4

50m ohm Max for other

contacts Mechanical

Characteristics:

Mating Force: 35

Newtoms. Maximum Unmating

Force: 10 Newtoms. Minimum.

PLATING: 8N Min After

Durability

Contact: Gold flash Plated

on contact ared

Tin

Plated 80u" Min on solder

area [Salt 8h] Nickel 50u" Min

underplating over all

Shell: Nickel

Plated 50" Min [Salt 24h] operating

Temperature -55to+85°

2±0.1 7±0.1 2.5±0.1

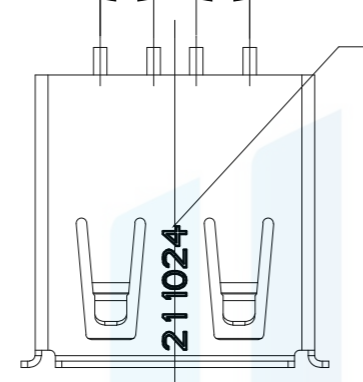

DATE CODE

XX XXXX

Week: 1024 表示第10月24号

Year: 21=2021

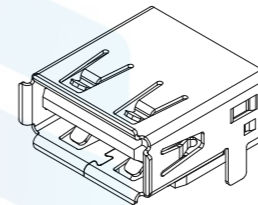

3D VIEW

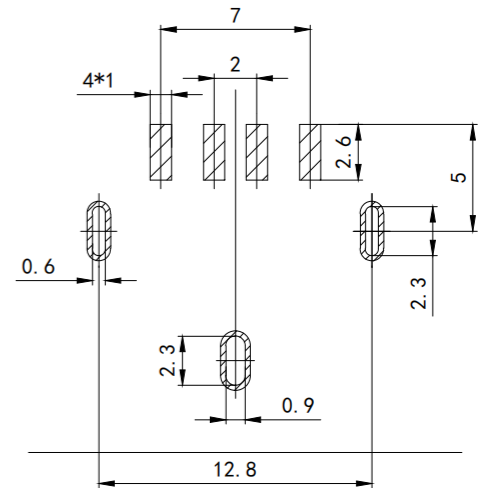
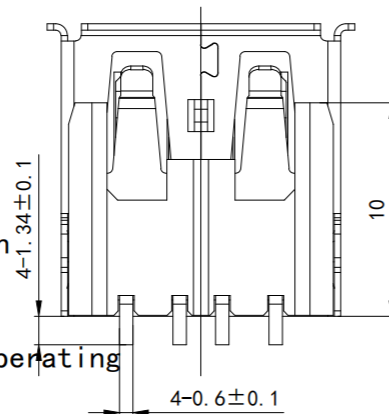
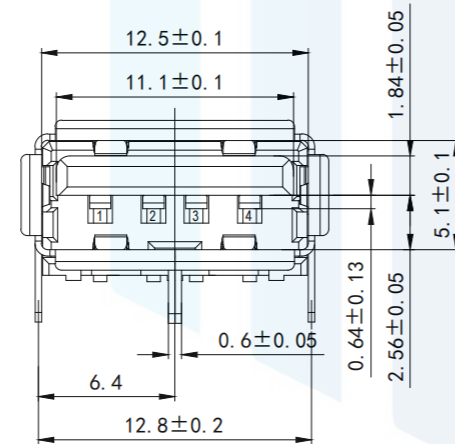

Recommended P C B Layout
TOP VIEW (TOLRANCE: ±0.05)

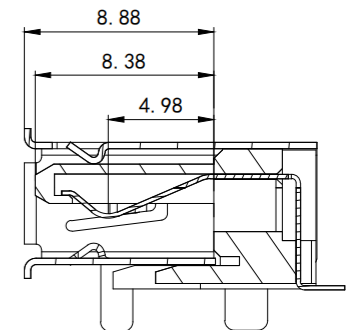
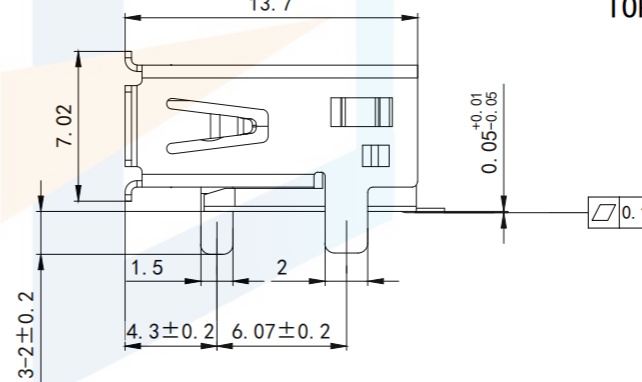

TOLERANCE

X. XXX	±0.05
X. XX	±0.15
X. X	±0.20
X.	±0.30
ANGLE	±5.0°

PROTECTON

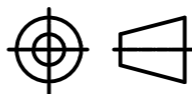

东莞市恒祺电子科技有限公司

Dongguan Hengqi Electronic Technology Co., Ltd

<https://www.hq-dz.com>

phone: 15812872448

TITLE:

USB A/F板上端子SMT卷边
3脚订位插板

PART NO: USB2.0-A466

DRAWING NO: 13.7*12.5*7.02

DRAWN:

CHECKED:

APPROVED:

DATE:

DATE:

DATE:

18-10-08

18-10-08

18-10-08

UNIT:
mm

SCALE:
FULL

SIZE:
A4