

RoHS2.0
Compliant

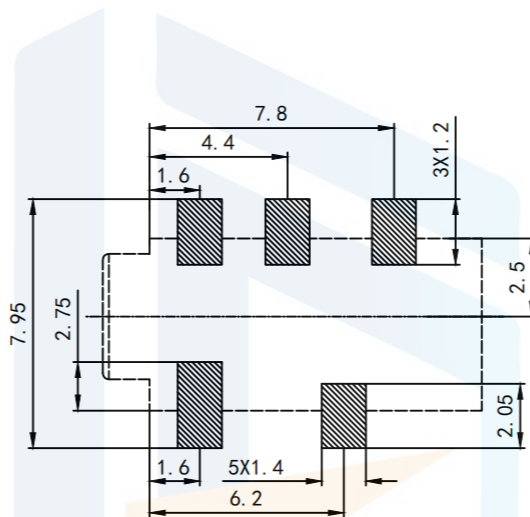

PCB LAYOUT TOP VIEW

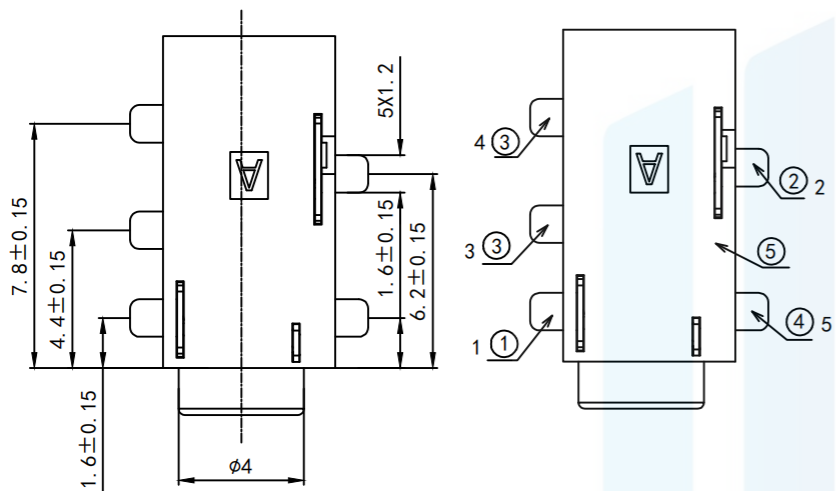
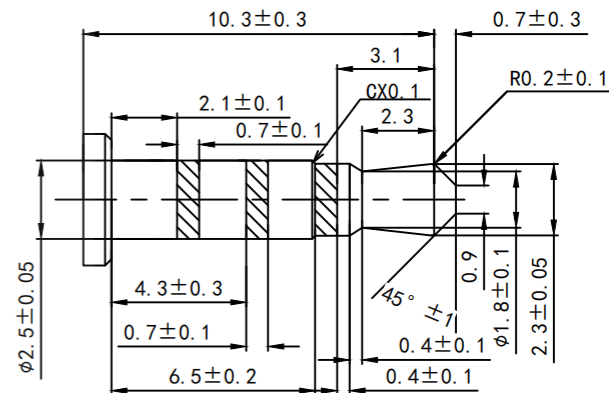

φ2.5mm 4 POLE PLUG DETAIL DRAWING

SPECIFICATION

1. Rating: DC 30V, 0.5A
2. Contact resistance: <30mΩ
3. Insulation resistance: >100MΩ
4. Withstand voltage : 500VAC
5. Insertion and extraction force: 3-20N
6. life test: 5,000 cycles

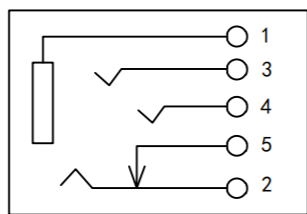
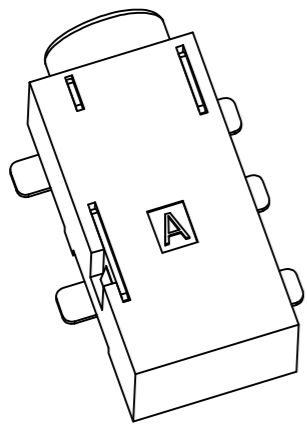
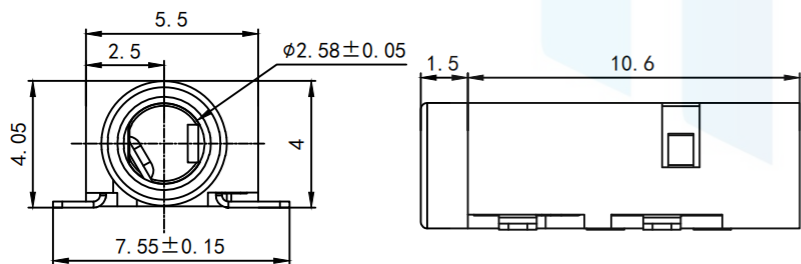

CIRCUIT DIAGRAM

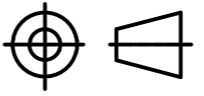
TOLERANCE X. XXX ±0.05 X. XX ±0.15 X. X ±0.20 X. ±0.30 ANGLE ±5.0°	 东莞市恒祺电子科技有限公司 Dongguan Hengqi Electronic Technology Co., Ltd	https://www.hq-dz.com phone:15812872448	
		TITLE: 耳机插座	
PROTECTON 	DRAWN:	PART NO: PH-2547	
	CHECKED:	DRAWING NO: 12*5.5*4.05	
	APPROVED:	DATE: 18-10-08	UNIT: mm
		DATE: 18-10-08	SCALE: FULL
		DATE: 18-10-08	SIZE: A4